

Teaching Electromagnetic Field Theory Using Differential Forms

Karl F. Warnick, Richard Selfridge and David V. Arnold

Abstract

The calculus of differential forms has significant advantages over traditional methods as a tool for teaching electromagnetic (EM) field theory: First, forms clarify the relationship between field intensity and flux density, by providing distinct mathematical and graphical representations for the two types of fields. Second, Ampere's and Faraday's laws obtain graphical representations that are as intuitive as the representation of Gauss's law. Third, the vector Stokes theorem and the divergence theorem become special cases of a single relationship that is easier for the student to remember, apply, and visualize than their vector formulations. Fourth, computational simplifications result from the use of forms: derivatives are easier to employ in curvilinear coordinates, integration becomes more straightforward, and families of vector identities are replaced by algebraic rules. In this paper, EM theory and the calculus of differential forms are developed in parallel, from an elementary, conceptually-oriented point of view using simple examples and intuitive motivations. We conclude that because of the power of the calculus of differential forms in conveying the fundamental concepts of EM theory, it provides an attractive and viable alternative to the use of vector analysis in teaching electromagnetic field theory.

I. INTRODUCTION

Certain questions are often asked by students of electromagnetic (EM) field theory: Why does one need both field intensity and flux density to describe a single field? How does one visualize the curl operation? Is there some way to make Ampere's law or Faraday's law as physically intuitive as Gauss's law? The Stokes theorem and the divergence theorem seem vaguely similar; do they have a deeper connection? Because of difficulty with concepts related to these questions, some students leave introductory courses lacking a real understanding of the physics of electromagnetics. Interestingly, none of these concepts are intrinsically more difficult than other aspects of EM theory; rather, they are unclear because of the limitations of the mathematical language traditionally used to teach electromagnetics: vector analysis. In this paper, we show that the calculus of differential forms clarifies these and other fundamental principles of electromagnetic field theory.

The use of the calculus of differential forms in electromagnetics has been explored in several important papers and texts, including Misner, Thorne, and Wheeler [1], Deschamps [2], and Burke [3]. These works note some of the advantages of the use of differential forms in EM theory. Misner *et al.* and Burke treat the graphical representation of forms and operations on forms, as well as other aspects of the application of forms to electromagnetics. Deschamps was among the first to advocate the use of forms in teaching engineering electromagnetics.

Existing treatments of differential forms in EM theory either target an advanced audience or are not intended to provide a complete exposition of the pedagogical advantages of differential forms. This paper presents the topic on an undergraduate level and emphasizes the benefits of differential forms in teaching introductory electromagnetics, especially graphical representations of forms and operators. The calculus of differential forms and principles of EM theory are introduced in parallel, much as would be done in a beginning EM course. We present concrete visual pictures of the various field quantities, Maxwell's laws, and boundary conditions. The aim of this paper is to demonstrate that differential forms are an attractive and viable alternative to vector analysis as a tool for teaching electromagnetic field theory.

A. Development of Differential Forms

Cartan and others developed the calculus of differential forms in the early 1900's. A differential form is a quantity that can be integrated, including differentials. More precisely, a differential form is a fully covariant, fully antisymmetric tensor. The calculus of differential forms is a self-contained subset of tensor analysis.

Since Cartan's time, the use of forms has spread to many fields of pure and applied mathematics, from differential topology to the theory of differential equations. Differential forms are used by physicists in general relativity [1], quantum field theory [4], thermodynamics [5], mechanics [6], as well as electromagnetics. A section on differential forms is commonplace in mathematical physics texts [7], [8]. Differential forms have

been applied to control theory by Hermann [9] and others.

B. Differential Forms in EM Theory

The laws of electromagnetic field theory as expressed by James Clerk Maxwell in the mid 1800's required dozens of equations. Vector analysis offered a more convenient tool for working with EM theory than earlier methods. Tensor analysis is in turn more concise and general, but is too abstract to give students a conceptual understanding of EM theory. Weyl first expressed Maxwell's laws using differential forms shortly after Cartan's work. Applied to electromagnetics, differential forms combine much of the generality of tensors with the simplicity and concreteness of vectors.

General treatments of differential forms and EM theory include papers [2], [10], [11], [12], [13], and [14]. Ingarden and Jamiołkowski [15] is an electrodynamics text using a mix of vectors and differential forms. Parrott [16] employs differential forms to treat advanced electrodynamics. Thirring [17] is a classical field theory text that includes certain applied topics such as waveguides. Bamberg and Sternberg [5] develop a range of topics in mathematical physics, including EM theory via an interesting discussion of discrete forms and circuit theory. Burke [3] treats a range of physics topics using forms, shows how to graphically represent forms, and gives a useful discussion of twisted differential forms. The general relativity text by Misner, Thorne and Wheeler [1] has several chapters on EM theory and differential forms, emphasizing the graphical representation of forms. Flanders [6] treats the calculus of forms and various applications, briefly mentioning electromagnetics.

We note here that many authors, including most of those referenced above, give the spacetime formulation of Maxwell's laws using forms, in which time is included as a differential. We use only the (3+1) representation in this paper, since the spacetime representation is treated in many references and is not as convenient for various elementary and applied topics. Still other formalisms for EM theory are available, including bivectors, quaternions, spinors, and higher Clifford algebras. None of these offer the combination of concrete graphical representations, ease of presentation, and close relationship to traditional vector methods that the calculus of differential forms brings to undergraduate-level electromagnetics.

The tools of applied electromagnetics have begun to be reformulated using differential forms. The authors have developed a convenient representation of electromagnetic boundary conditions [18]. Thirring [17] treats several applications of EM theory using forms. Reference [19] treats the dyadic Green function using differential forms. Work is also proceeding on the use of Green forms for anisotropic media [20].

C. Pedagogical Advantages of Differential Forms

As a language for teaching electromagnetics, differential forms offer several important advantages over vector analysis. Vector analysis allows only two types of quantities: scalar fields and vector fields (ignoring inversion properties). In a three-dimensional space, differential forms of four different types are available.

This allows flux density and field intensity to have distinct mathematical expressions and graphical representations, providing the student with mental pictures that clearly reveal the different properties of each type of quantity. The physical interpretation of a vector field is often implicitly contained in the choice of operator or integral that acts on it. With differential forms, these properties are directly evident in the type of form used to represent the quantity.

The basic derivative operators of vector analysis are the gradient, curl and divergence. The gradient and divergence lend themselves readily to geometric interpretation, but the curl operation is more difficult to visualize. The gradient, curl and divergence become special cases of a single operator, the exterior derivative and the curl obtains a graphical representation that is as clear as that for the divergence. The physical meanings of the curl operation and the integral expressions of Faraday's and Ampere's laws become so intuitive that the usual order of development can be reversed by introducing Faraday's and Ampere's laws to students first and using these to motivate Gauss's laws.

The Stokes theorem and the divergence theorem have an obvious connection in that they relate integrals over a boundary to integrals over the region inside the boundary, but in the language of vector analysis they appear very different. These theorems are special cases of the generalized Stokes theorem for differential forms, which also has a simple graphical interpretation.

Since 1992, we have incorporated short segments on differential forms into our beginning, intermediate, and graduate electromagnetics courses. In the Fall of 1995, we reworked the entire beginning electromagnetics course, changing emphasis from vector analysis to differential forms. Following the first semester in which the new curriculum was used, students completed a detailed written evaluation. Out of 44 responses, four were partially negative; the rest were in favor of the change to differential forms. Certainly, enthusiasm of students involved in something new increased the likelihood of positive responses, but one fact was clear: pictures of differential forms helped students understand the principles of electromagnetics.

D. Outline

Section II defines differential forms and the degree of a form. Graphical representations for forms of each degree are given, and the differential forms representing the various quantities of electromagnetics are identified. In Sec. III we use these differential forms to express Maxwell's laws in integral form and give graphical interpretations for each of the laws. Section IV introduces differential forms in curvilinear coordinate systems. Section V applies Maxwell's laws to find the fields due to sources of basic geometries. In Sec. VI we define the exterior derivative, give the generalized Stokes theorem, and express Maxwell's laws in point form. Section VII treats boundary conditions using the interior product. Section VIII provides a summary of the main points made in the paper.

II. DIFFERENTIAL FORMS AND THE ELECTROMAGNETIC FIELD

In this section we define differential forms of various degrees and identify them with field intensity, flux density, current density, charge density and scalar potential.

A differential form is a quantity that can be integrated, including differentials. $3x dx$ is a differential form, as are $x^2y dx dy$ and $f(x, y, z) dy dz + g(x, y, z) dz dx$. The type of integral called for by a differential form determines its degree. The form $3x dx$ is integrated under a single integral over a path and so is a 1-form. The form $x^2y dx dy$ is integrated by a double integral over a surface, so its degree is two. A 3-form is integrated by a triple integral over a volume. 0-forms are functions, "integrated" by evaluation at a point. Table I gives examples of forms of various degrees. The coefficients of the forms can be functions of position, time, and other variables.

TABLE I
DIFFERENTIAL FORMS OF EACH DEGREE.

Degree	Region of Integration	Example	General Form
0-form	Point	$3x$	$f(x, y, z, \dots)$
1-form	Path	$y^2 dx + z dy$	$\alpha_1 dx + \alpha_2 dy + \alpha_3 dz$
2-form	Surface	$e^y dy dz + e^x g dz dx$	$\beta_1 dy dz + \beta_2 dz dx + \beta_3 dx dy$
3-form	Volume	$(x + y) dx dy dz$	$g dx dy dz$

A. Representing the Electromagnetic Field with Differential Forms

From Maxwell's laws in integral form, we can readily determine the degrees of the differential forms that will represent the various field quantities. In vector notation,

$$\begin{aligned} \oint_P \mathbf{E} \cdot d\mathbf{l} &= -\frac{\partial}{\partial t} \int_A \mathbf{B} \cdot d\mathbf{A} \\ \oint_P \mathbf{H} \cdot d\mathbf{l} &= \frac{\partial}{\partial t} \int_A \mathbf{D} \cdot d\mathbf{A} + \int_A \mathbf{J} \cdot d\mathbf{A} \\ \oint_S \mathbf{D} \cdot d\mathbf{S} &= \int_V q dv \\ \oint_S \mathbf{B} \cdot d\mathbf{S} &= 0 \end{aligned}$$

where A is a surface bounded by a path P , V is a volume bounded by a surface S , q is volume charge density, and the other quantities are defined as usual. The electric field intensity is integrated over a path, so that it becomes a 1-form. The magnetic field intensity is also integrated over a path, and becomes a 1-form as well. The electric and magnetic flux densities are integrated over surfaces, and so are 2-forms. The sources are electric current density, which is a 2-form, since it falls under a surface integral, and the volume charge density, which is a 3-form, as it is integrated over a volume. Table II summarizes these forms.

TABLE II
THE DIFFERENTIAL FORMS THAT REPRESENT FIELDS AND SOURCES.

Quantity	Form	Degree	Units	Vector/Scalar
Electric Field Intensity	E	1-form	V	E
Magnetic Field Intensity	H	1-form	A	H
Electric Flux Density	D	2-form	C	D
Magnetic Flux Density	B	2-form	Wb	B
Electric Current Density	J	2-form	A	J
Electric Charge Density	ρ	3-form	C	q

B. 1-Forms; Field Intensity

The usual physical motivation for electric field intensity is the force experienced by a small test charge placed in the field. This leads naturally to the vector representation of the electric field, which might be called the “force picture.” Another physical viewpoint for the electric field is the change in potential experienced by a charge as it moves through the field. This leads naturally to the equipotential representation of the field, or the “energy picture.” The energy picture shifts emphasis from the local concept of force experienced by a test charge to the global behavior of the field as manifested by change in energy of a test charge as it moves along a path.

Differential forms lead to the “energy picture” of field intensity. A 1-form is represented graphically as surfaces in space [1], [3]. For a conservative field, the surfaces of the associated 1-form are equipotentials. The differential dx produces surfaces perpendicular to the x -axis, as shown in Fig. 1a. Likewise, dy has surfaces perpendicular to the y -axis and the surfaces of dz are perpendicular to the z axis. A linear combination of these differentials has surfaces that are skew to the coordinate axes. The coefficients of a 1-form determine the spacing of the surfaces per unit length; the greater the magnitude of the coefficients, the more closely spaced are the surfaces. The 1-form $2dz$, shown in Fig. 1b, has surfaces spaced twice as closely as those of dz in Fig. 1a.

In general, the surfaces of a 1-form can curve, end, or meet each other, depending on the behavior of the coefficients of the form. If surfaces of a 1-form do not meet or end, the field represented by the form is conservative. The field corresponding to the 1-form in Fig. 1a is conservative; the field in Fig. 1c is nonconservative.

Just as a line representing the magnitude of a vector has two possible orientations, the surfaces of a 1-form are oriented as well. This is done by specifying one of the two normal directions to the surfaces of the form. The surfaces of $3dx$ are oriented in the $+x$ direction, and those of $-3dx$ in the $-x$ direction. The orientation of a form is usually clear from context and is omitted from figures.

Differential forms are by definition the quantities that can be integrated, so it is natural that the surfaces of a 1-form are a graphical representation of path integration. The integral of a 1-form along a path is the

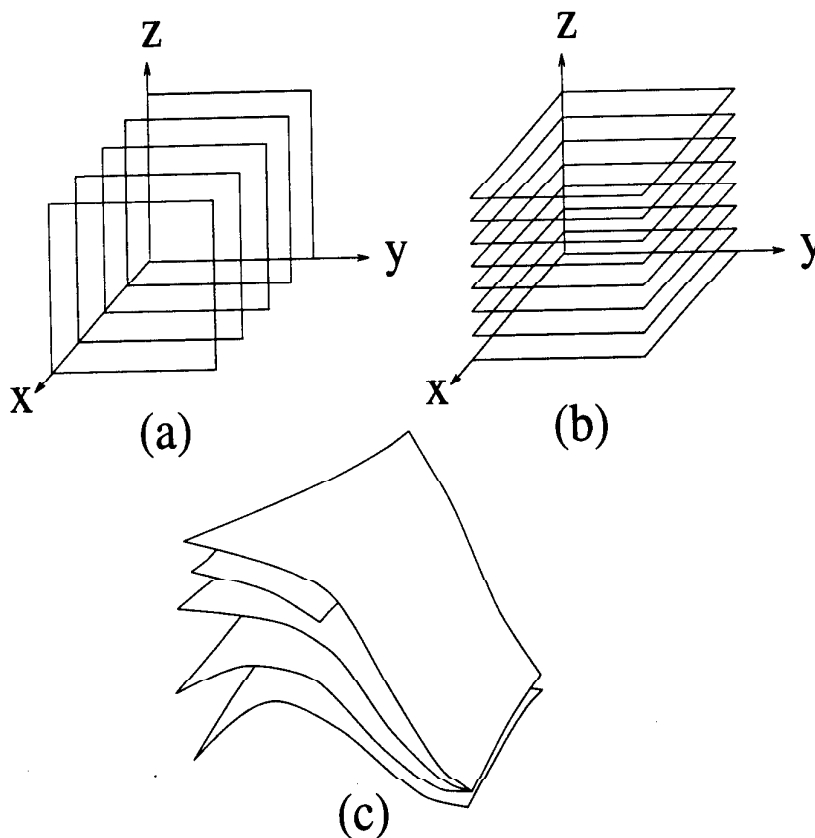

Fig. 1 (a) The 1-form dx , with surfaces perpendicular to the x axis and infinite in the y and z directions. (b) The 1-form $2 dz$, with surfaces perpendicular to the z -axis and spaced two per unit distance in the z direction. (c) A general 1-form, with curved surfaces and surfaces that end or meet each other.

number of surfaces pierced by the path (Fig. 2), taking into account the relative orientations of the surfaces and the path. This simple picture of path integration will provide in the next section a means for visualizing Ampere's and Faraday's laws.

The 1-form $E_1 dx + E_2 dy + E_3 dz$ is said to be *dual* to the vector field $E_1 \hat{x} + E_2 \hat{y} + E_3 \hat{z}$. The field intensity 1-forms E and H are dual to the vectors \mathbf{E} and \mathbf{H} .

Following Deschamps, we take the units of the electric and magnetic field intensity 1-forms to be Volts and Amps, considering the differentials to have units of length, as shown in Table II. Other field and source quantities are assigned units according to this same convention. Alternative conventions are available; Bamberg and Sternberg [5] and others take the units of the electric and magnetic field intensity 1-forms to be V/m and A/m, the same as their vector counterparts, so that the differentials carry no units and the integration process itself is considered to provide a factor of length. If this convention is chosen, the basis differentials of curvilinear coordinate systems (see Sec. IV) must also be taken to carry no units. This leads

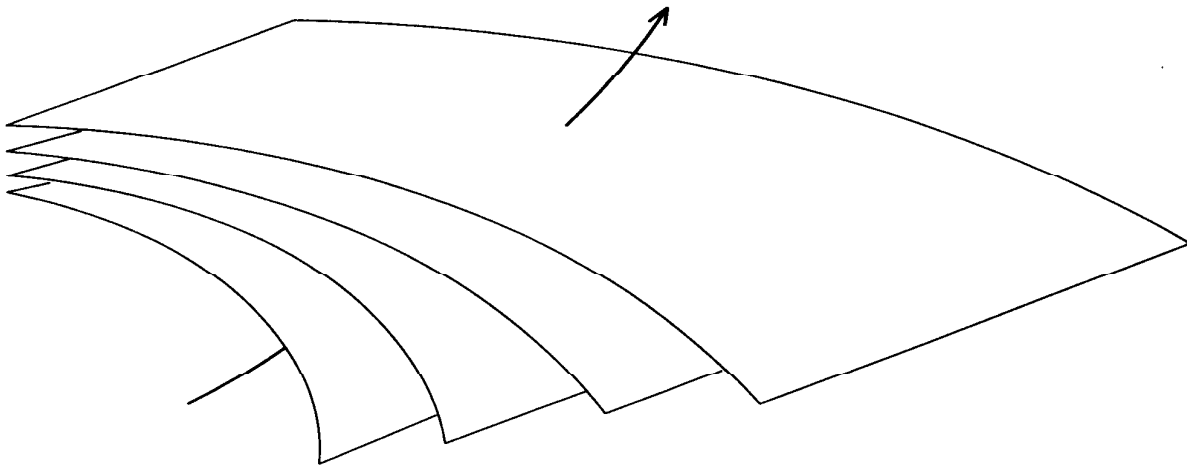

Fig. 2. A path piercing four surfaces of a 1-form. The integral of the 1-form over the path is four.

to confusion for students, since these basis differentials can include factors of distance. The advantages of this convention are that it is more consistent with the mathematical point of view, in which basis vectors and forms are abstract objects not associated with a particular system of units, and that a field quantity has the same units whether represented by a vector or a differential form. The possibility of confusion when using curvilinear coordinates seems to outweigh these points, and we choose Deschamps' convention.

With this convention, the electric field intensity 1-form can be taken to have units of energy per charge, or J/C. This supports the "energy picture," in which the electric field represents the change in energy experienced by a charge as it moves through the field. One might argue that this motivation of field intensity is less intuitive than the concept of force experienced by a test charge at a point. While this may be true, the graphical representations of Ampere's and Faraday's laws that will be outlined in Sec. III favor the differential form point of view. Furthermore, the simple correspondence between vectors and forms allows both to be introduced with little additional effort, providing students a more solid understanding of field intensity than they could obtain from one representation alone.

C. 2-Forms; Flux Density and Current Density

Flux density or flow of current can be thought of as tubes that connect sources of flux or current. This is the natural graphical representation of a 2-form, which is drawn as sets of surfaces that intersect to form tubes. The differential $dx dy$ is represented by the surfaces of dx and dy superimposed. The surfaces of dx perpendicular to the x -axis and those of dy perpendicular to the y -axis intersect to produce tubes in the z direction, as illustrated by Fig. 3a. (To be precise, the tubes of a 2-form have no definite shape: tubes of $dx dy$ have the same density those of $[.5 dx][2 dy]$.) The coefficients of a 2-form give the spacing of the tubes. The greater the coefficients, the more dense the tubes. An arbitrary 2-form has tubes that may curve or

converge at a point.

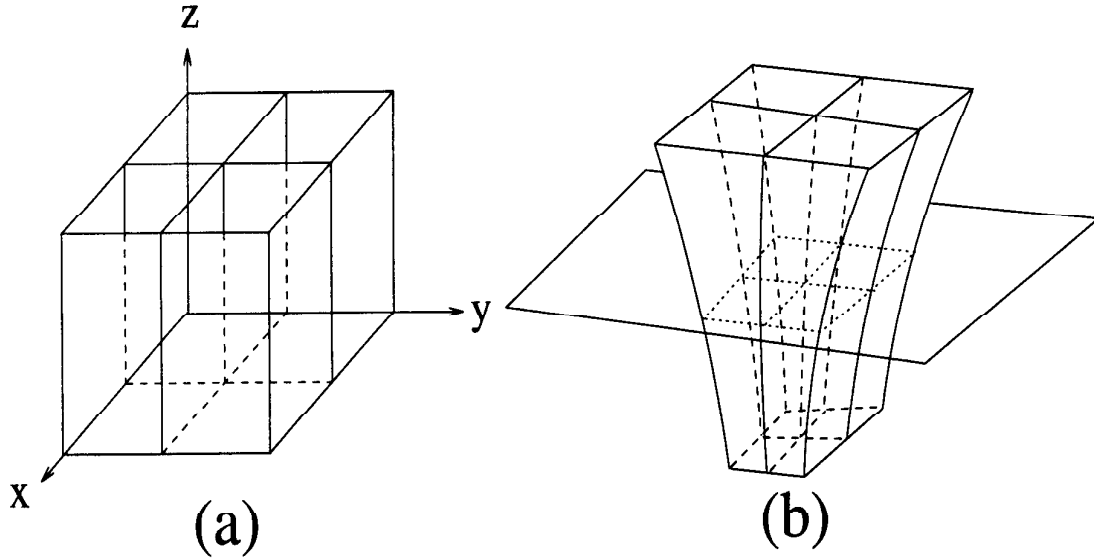

Fig. 3. (a) The 2-form $dx dy$, with tubes in the z direction. (b) Four tubes of a 2-form pass through a surface, so that the integral of the 2-form over the surface is four.

The direction of flow or flux along the tubes of a 2-form is given by the right-hand rule applied to the orientations of the surfaces making up the walls of a tube. The orientation of dx is in the $+x$ direction, and dy in the $+y$ direction, so the flux due to $dx dy$ is in the $+z$ direction.

As with 1-forms, the graphical representation of a 2-form is fundamentally related to the integration process. The integral of a 2-form over a surface is the number of tubes passing through the surface, where each tube is weighted positively if its orientation is in the direction of the surface's orientation, and negatively if opposite. This is illustrated in Fig. 3b.

As with 1-forms, 2-forms correspond to vector fields in a simple way. An arbitrary 2-form $D_1 dy dz + D_2 dz dx + D_3 dx dy$ is dual to the vector field $D_1 \hat{x} + D_2 \hat{y} + D_3 \hat{z}$, so that the flux density 2-forms D and B are dual to the usual flux density vectors \mathbf{D} and \mathbf{B} .

D. 3-Forms; Charge Density

Some scalar physical quantities are densities, and can be integrated over a volume. For other scalar quantities, such as electric potential, a volume integral makes no sense. The calculus of forms distinguishes between these two types of quantities by representing densities as 3-forms. Volume charge density, for example, becomes

$$\rho = q dx dy dz \tag{1}$$

where q is the usual scalar charge density in the notation of [2].

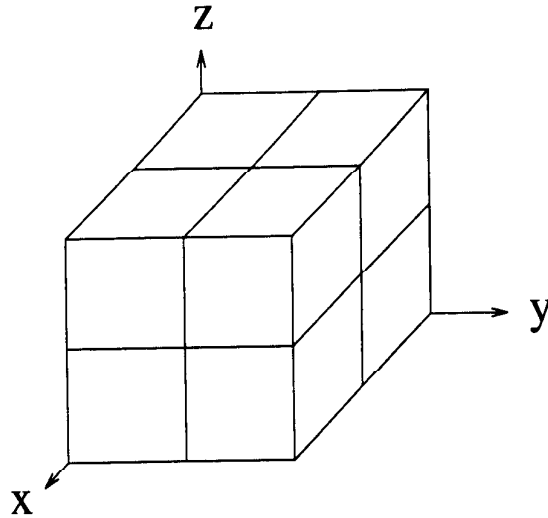

Fig. 4. The 3-form $dx dy dz$, with cubes of side equal to one. The cubes fill all space.

A 3-form is represented by three sets of surfaces in space that intersect to form boxes. The density of the boxes is proportional to the coefficient of the 3-form; the greater the coefficient, the smaller and more closely spaced are the boxes. A point charge is represented by an infinitesimal box at the location of the charge. The 3-form $dx dy dz$ is the union of three families of planes perpendicular to each of the x , y and z axes. The planes along each of the axes are spaced one unit apart, forming cubes of unit side distributed evenly throughout space, as in Fig. 4. The orientation of a 3-form is given by specifying the sign of its boxes. As with other differential forms, the orientation is usually clear from context and is omitted from figures.

E. 0-forms; Scalar Potential

0-forms are functions. The scalar potential ϕ , for example, is a 0-form. Any scalar physical quantity that is not a volume density is represented by a 0-form.

F. Summary

The use of differential forms helps students to understand electromagnetics by giving them distinct mental pictures that they can associate with the various fields and sources. As vectors, field intensity and flux density are mathematically and graphically indistinguishable as far as the type of physical quantity they represent. As differential forms, the two types of quantities have graphical representations that clearly express the physical meaning of the field. The surfaces of a field intensity 1-form assign potential change to a path. The tubes of a flux density 2-form give the total flux or flow through a surface. Charge density is also distinguished from other types of scalar quantities by its representation as a 3-form.

III. MAXWELL'S LAWS IN INTEGRAL FORM

In this section, we discuss Maxwell's laws in integral form in light of the graphical representations given in the previous section. Using the differential forms defined in Table II, Maxwell's laws can be written

$$\begin{aligned}\oint_P E &= -\frac{\partial}{\partial t} \int_A B \\ \oint_P H &= \frac{\partial}{\partial t} \int_A D + \int_A J \\ \oint_S D &= \int_V \rho \\ \oint_S B &= 0.\end{aligned}\tag{2}$$

The first pair of laws is often more difficult for students to grasp than the second, because the vector picture of curl is not as intuitive as that for divergence. With differential forms, Ampere's and Faraday's laws are graphically very similar to Gauss's laws for the electric and magnetic fields. The close relationship between the two sets of laws becomes clearer.

A. Ampere's and Faraday's Laws

Faraday's and Ampere's laws equate the number of surfaces of a 1-form pierced by a closed path to the number of tubes of a 2-form passing through the path. Each tube of J , for example, must have a surface of H extending away from it, so that any path around the tube pierces the surface of H . Thus, Ampere's law states that tubes of displacement current and electric current are sources for surfaces of H . This is illustrated in Fig. 5a. Likewise, tubes of time-varying magnetic flux density are sources for surfaces of E .

The illustration of Ampere's law in Fig. 5a is arguably the most important pedagogical advantage of the calculus of differential forms over vector analysis. Ampere's and Faraday's laws are usually considered the more difficult pair of Maxwell's laws, because vector analysis provides no simple picture that makes the physical meaning of these laws intuitive. Compare Fig. 5a to the vector representation of the same field in Fig. 5b. The vector field appears to "curl" everywhere in space. Students must be convinced that indeed the field has no curl except at the location of the current, using some pedagogical device such as an imaginary paddle wheel in a rotating fluid. The surfaces of H , on the other hand, end only along the tubes of current; where they do not end, the field has no curl. This is the fundamental concept underlying Ampere's and Faraday's laws: tubes of time varying flux or current produce field intensity surfaces.

B. Gauss's Laws

Gauss's law for the electric field states that the number of tubes of D flowing out through a closed surface must be equal to the number of boxes of ρ inside the surface. The boxes of ρ are sources for the tubes of D , as shown in Fig. 6. Gauss's law for the magnetic flux density states that tubes of the 2-form B can never end—they must either form closed loops or go off to infinity.

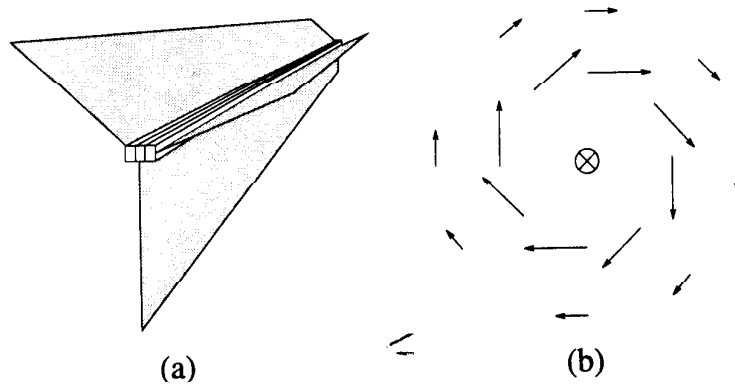

Fig. 5. (a) A graphical representation of Ampere's law: tubes of current produce surfaces of magnetic field intensity. Any loop around the three tubes of J must pierce three surfaces of H . (b) A cross section of the same magnetic field using vectors. The vector field appears to "curl" everywhere, even though the field has nonzero curl only at the location of the current.

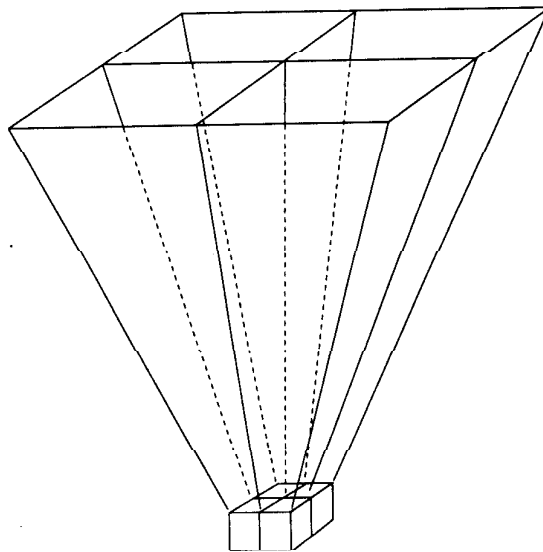

Fig. 6. A graphical representation of Gauss's law for the electric flux density: boxes of ρ produce tubes of D .

Comparing Figs. 5a and 6 shows the close relationship between the two sets of Maxwell's laws. In the same way that flux density tubes are produced by boxes of electric charge, field intensity surfaces are produced by tubes of the sources on the right-hand sides of Faraday's and Ampere's laws. Conceptually, the laws only differ in the degrees of the forms involved and the dimensions of their pictures.

C. Constitutive Relations and the Star Operator

The usual vector expressions of the constitutive relations for an isotropic medium,

$$\mathbf{D} = \epsilon \mathbf{E}$$

$$\mathbf{B} = \mu\mathbf{H},$$

involve scalar multiplication. With differential forms, we cannot use these same relationships, because D and B are 2-forms, while E and H are 1-forms. An operator that relates forms of different degrees must be introduced.

The Hodge star operator [5], [17] naturally fills this role. As vector spaces, the spaces of 0-forms and 3-forms are both one-dimensional, and the spaces of 1-forms and 2-forms are both three-dimensional. The star operator \star is a set of isomorphisms between these pairs of vector spaces.

For 1-forms and 2-forms, the star operator satisfies

$$\begin{aligned}\star dx &= dy dz \\ \star dy &= dz dx \\ \star dz &= dx dy.\end{aligned}$$

0-forms and 3-forms are related by

$$\star 1 = dx dy dz.$$

In R^3 , the star operator is its own inverse, so that $\star\star\alpha = \alpha$. A 1-form ω is dual to the same vector as the 2-form $\star\omega$.

Graphically, the star operator replaces the surfaces of a form with orthogonal surfaces, as in Fig. 7. The 1-form $3 dx$, for example, has planes perpendicular to the x -axis. It becomes $3 dy dz$ under the star operation. This 2-form has planes perpendicular to the y and the z axes.

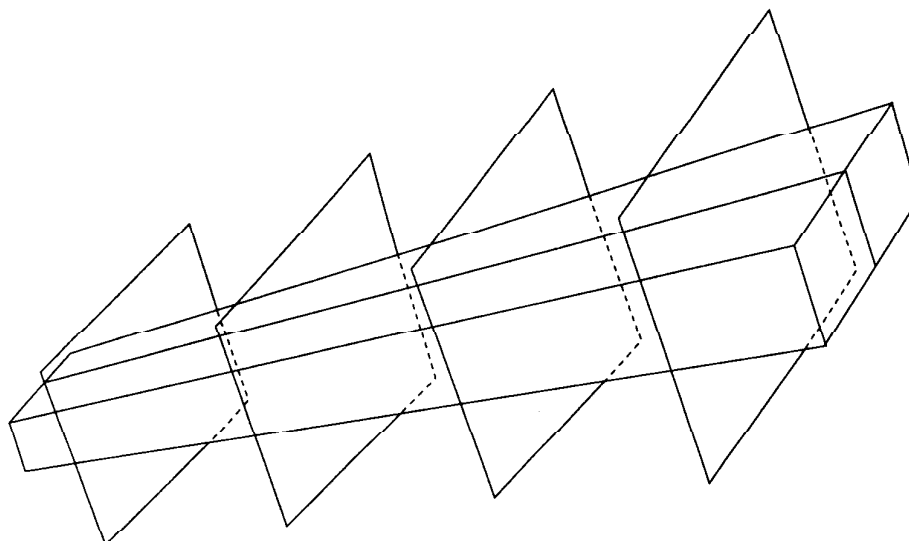

Fig. 7. The star operator relates 1-form surfaces to perpendicular 2-form tubes.

Using the star operator, the constitutive relations are

$$D = \epsilon \star E \quad (3)$$

$$B = \mu \star H \quad (4)$$

where ϵ and μ are the permittivity and permeability of the medium. The surfaces of E are perpendicular to the tubes of D , and the surfaces of H are perpendicular to the tubes of B . The following example illustrates the use of these relations.

Example 1. Finding D due to an electric field intensity.

Let $E = (dx + dy)e^{ik(x-y)}$ V be the electric field in free space. We wish to find the flux due to the field. Using the constitutive relationship between D and E ,

$$\begin{aligned} D &= \epsilon_0 \star (dx + dy)e^{ik(x-y)} \\ &= \epsilon_0 e^{ik(x-y)} (\star dx + \star dy) \\ &= \epsilon_0 e^{ik(x-y)} (dy dz + dz dx) \quad \text{C.} \end{aligned}$$

While we restrict our attention to isotropic media in this paper, the star operator applies equally well to anisotropic media. As discussed in Ref. [5] and elsewhere, the star operator depends on a metric. If the metric is taken to be the permittivity or the permeability tensor, anisotropic star operators are obtained, and the constitutive relations become $D = \star_e E$ and $B = \star_h H$ [20]. Graphically, an anisotropic star operator acts on 1-form surfaces to produce 2-form tubes that intersect the surfaces obliquely rather than orthogonally.

D. The Exterior Product and the Poynting 2-form

Between the differentials of 2 forms and 3-forms is an implied exterior product, denoted by a wedge \wedge . The wedge is nearly always omitted from the differentials of a form, especially when the form appears under an integral sign. The exterior product of 1-forms is anticommutative, so that $dx \wedge dy = -dy \wedge dx$. As a consequence, the exterior product is in general supercommutative:

$$\alpha \wedge \beta = (-1)^{ab} \beta \wedge \alpha \quad (5)$$

where a and b are the degrees of α and β , respectively. One usually converts the differentials of a form to right-cyclic order using (5).

As a consequence of (5), any differential form with a repeated differential vanishes. In a three-dimensional space each term of a p -form will always contain a repeated differential if $p > 3$, so there are no nonzero p -forms for $p > 3$.

The exterior product of two 1-forms is analogous to the vector cross product. With vector analysis, it is not obvious that the cross product of vectors is a different type of quantity than the factors. Under coordinate inversion, $\mathbf{a} \times \mathbf{b}$ changes sign relative to a vector with the same components, so that $\mathbf{a} \times \mathbf{b}$ is a pseudovector. With forms, the distinction between $a \wedge b$ and a or b individually is clear.

The exterior product of a 1-form and a 2-form corresponds to the dot product. The coefficient of the resulting 3-form is equal to the dot product of the vector fields dual to the 1-form and 2-form.

Combinations of cross and dot products are somewhat difficult to manipulate algebraically, often requiring the use of tabulated identities. Using the supercommutativity of the exterior product, the student can easily manipulate arbitrary products of forms. For example, the identities

$$\mathbf{A} \cdot (\mathbf{B} \times \mathbf{C}) = \mathbf{C} \cdot (\mathbf{A} \times \mathbf{B}) = \mathbf{B} \cdot (\mathbf{C} \times \mathbf{A})$$

are special cases of

$$A \wedge B \wedge C = C \wedge A \wedge B = B \wedge C \wedge A$$

where A , B and C are forms of arbitrary degrees. The factors can be interchanged easily using (5).

Consider the exterior product of the 1-forms E and H ,

$$\begin{aligned} E \wedge H &= (E_1 dx + E_2 dy + E_3 dz) \wedge (H_1 dx + H_2 dy + H_3 dz) \\ &= E_1 H_1 dx dx + E_1 H_2 dx dy + E_1 H_3 dx dz \\ &\quad + E_2 H_1 dy dx + E_2 H_2 dy dy + E_2 H_3 dy dz \\ &\quad + E_3 H_1 dz dx + E_3 H_2 dz dy + E_3 H_3 dz dz \\ &= (E_2 H_3 - E_3 H_2) dy dz + (E_3 H_1 - E_1 H_3) dz dx + (E_1 H_2 - E_2 H_1) dx dy. \end{aligned}$$

This is the Poynting 2-form S . For complex fields, $S = E \wedge H^*$. For time-varying fields, the tubes of this 2-form represent flow of electromagnetic power, as shown in Fig. 8. The sides of the tubes are the surfaces of E and H . This gives a clear geometrical interpretation to the fact that the direction of power flow is orthogonal to the orientations of both E and H .

Example 2. The Poynting 2-form due to a plane wave.

Consider a plane wave propagating in free space in the z direction, with the time-harmonic electric field $E = E_0 dx$ V in the x direction. The Poynting 2-form is

$$\begin{aligned} S &= E \wedge H \\ &= E_0 dx \wedge \frac{E_0}{\eta_0} dy \\ &= \frac{E_0^2}{\eta_0} dx dy \quad \text{W} \end{aligned}$$

where η_0 is the wave impedance of free space.

E. Energy Density

The exterior products $E \wedge D$ and $H \wedge B$ are 3-forms that represent the density of electromagnetic energy. The energy density 3-form w is defined to be

$$w = \frac{1}{2} (E \wedge D + H \wedge B) \quad (6)$$

The volume integral of w gives the total energy stored in a region of space by the fields present in the region.

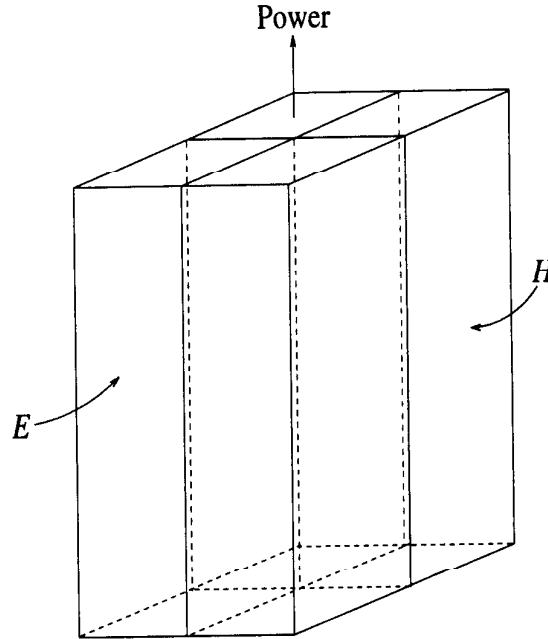

Fig. 8. The Poynting power flow 2-form $S = E \wedge H$. Surfaces of the 1-forms E and H are the sides of the tubes of S .

Fig. 9 shows the energy density 3-form between the plates of a capacitor, where the upper and lower plates are equally and oppositely charged. The boxes of $2w$ are the intersection of the surfaces of E , which are parallel to the plates, with the tubes of D , which extend vertically from one plate to the other.

IV. CURVILINEAR COORDINATE SYSTEMS

In this section, we give the basis differentials, the star operator, and the correspondence between vectors and forms for cylindrical, spherical, and generalized orthogonal coordinates.

A. Cylindrical Coordinates

The differentials of the cylindrical coordinate system are $d\rho$, $\rho d\phi$ and dz . Each of the basis differentials is considered to have units of length. The general 1-form

$$A d\rho + B \rho d\phi + C dz \quad (7)$$

is dual to the vector

$$A \hat{\rho} + B \hat{\phi} + C \hat{z}. \quad (8)$$

The general 2-form

$$A \rho d\phi \wedge dz + B dz \wedge d\rho + C d\rho \wedge \rho d\phi \quad (9)$$

is dual to the same vector. The 2-form $d\rho d\phi$, for example, is dual to the vector $(1/\rho) dz$.

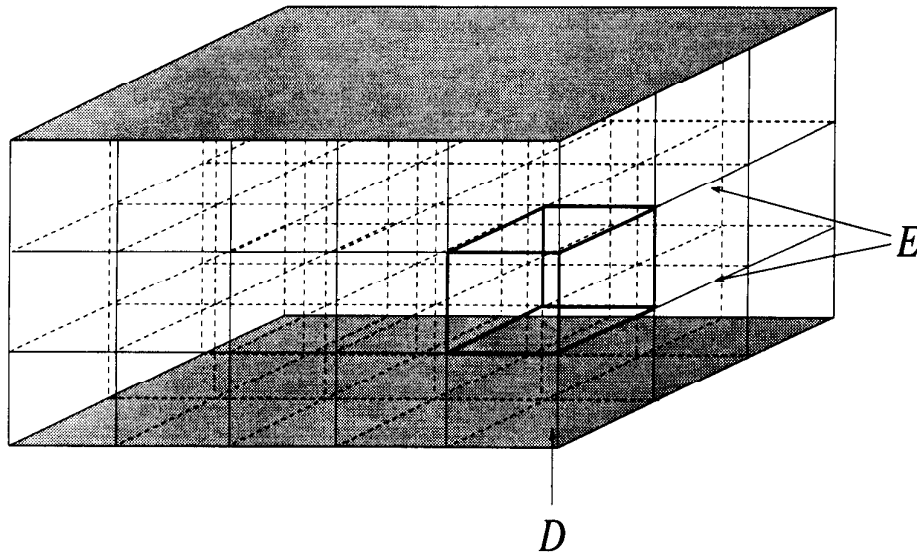

Fig. 9. The 3-form 2ω due to fields inside a parallel plate capacitor with oppositely charged plates. The surfaces of E are parallel to the top and bottom plates. The tubes of D extend vertically from charges on one plate to opposite charges on the other. The tubes and surfaces intersect to form cubes of 2ω , one of which is outlined in the figure.

Differentials must be converted to basis elements before the star operator is applied. The star operator in cylindrical coordinates acts as follows:

$$\begin{aligned} \star d\rho &= \rho d\phi \wedge dz \\ \star \rho d\phi &= dz \wedge d\rho \\ \star dz &= d\rho \wedge \rho d\phi. \end{aligned}$$

Also, $\star 1 = \rho d\rho d\phi dz$. As with the rectangular coordinate system, $\star\star = 1$. The star operator applied to $d\phi dz$, for example, yields $(1/\rho) d\rho$.

Fig. 10 shows the pictures of the differentials of the cylindrical coordinate system. The 2-forms can be obtained by superimposing these surfaces. Tubes of $dz \wedge d\rho$, for example, are square rings formed by the union of Figs. 10a and 10c.

B. Spherical Coordinates

The basis differentials of the spherical coordinate system are dr , $r d\theta$ and $r \sin \theta d\phi$, each having units of length. The 1-form

$$A dr + Br d\theta + Cr \sin \theta d\phi \tag{10}$$

and the 2-form

$$Ar d\theta \wedge r \sin \theta d\phi + Br \sin \theta d\phi \wedge dr + C dr \wedge r d\theta \tag{11}$$

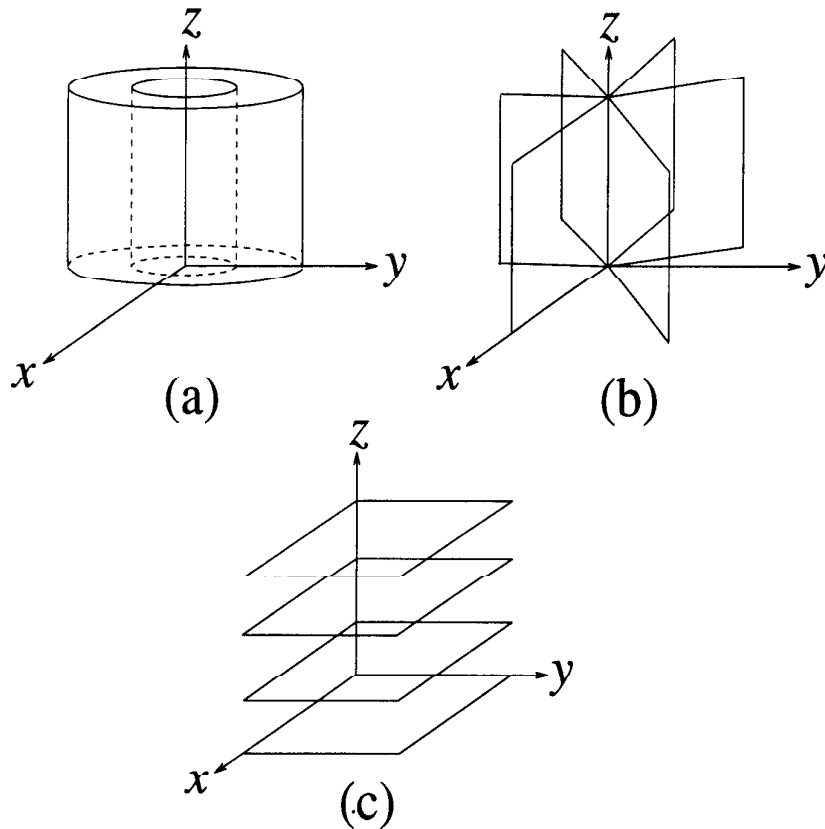

Fig. 10. Surfaces of (a) $d\rho$, (b) $d\phi$ scaled by $3/\pi$, and (c) dz .

are both dual to the vector

$$A\hat{r} + B\hat{\theta} + C\hat{\phi} \quad (12)$$

so that $d\theta d\phi$ is dual to the vector $\hat{r}/(r^2 \sin \theta)$.

As in the cylindrical coordinate system, differentials must be converted to basis elements before the star operator is applied. The star operator acts on 1-forms and 2-forms as follows:

$$\begin{aligned} \star dr &= r d\theta \wedge r \sin \theta d\phi \\ \star r d\theta &= r \sin \theta d\phi \wedge dr \\ \star r \sin \theta d\phi &= dr \wedge r d\theta \end{aligned}$$

Again, $\star\star = 1$. The star operator applied to one is $\star 1 = r^2 \sin \theta dr d\theta d\phi$. Fig. 11 shows the pictures of the differentials of the spherical coordinate system; pictures of 2-forms can be obtained by superimposing these surfaces.

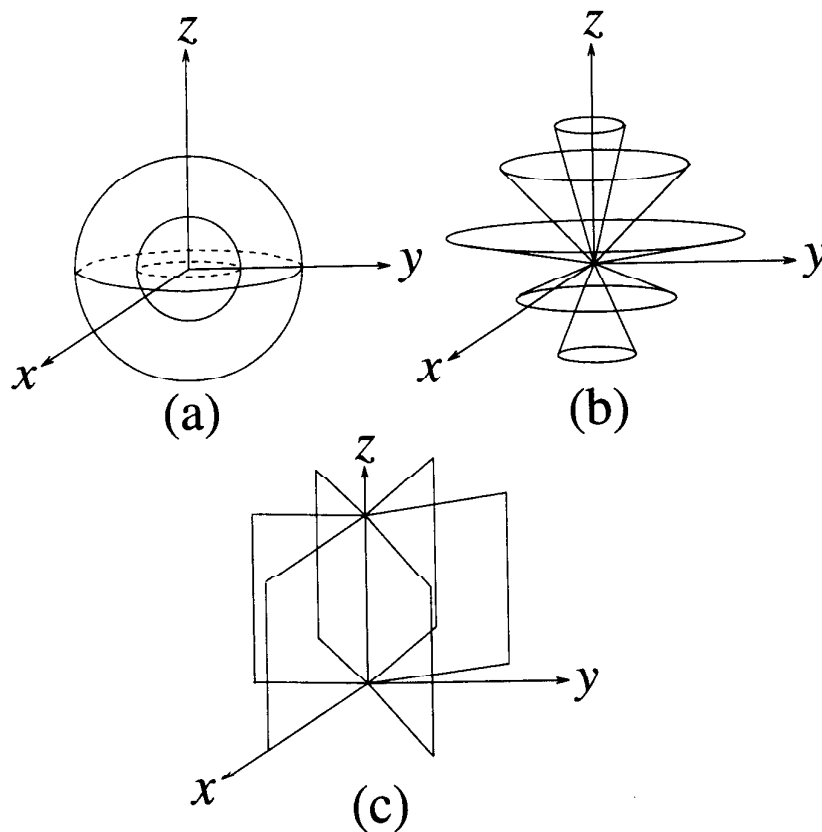

Fig. 11. Surfaces of (a) dr , (b) $d\theta$ scaled by $10/\pi$, and (c) $d\phi$ scaled by $3/\pi$.

C. Generalized Orthogonal Coordinates

Let the location of a point be given by (u, v, w) such that the tangents to each of the coordinates are mutually orthogonal. Define a function h_1 such that the integral of $h_1 du$ along any path with v and w constant gives the length of the path. Define h_2 and h_3 similarly. Then the basis differentials are

$$h_1 du, h_2 dv, h_3 dw. \quad (13)$$

The 1-form $Ah_1 du + Bh_2 dv + Ch_3 dw$ and the 2-form $Ah_2h_3 dv \wedge dw + Bh_3h_1 dw \wedge du + Ch_1h_2 du \wedge dv$ are both dual to the vector $A\hat{u} + B\hat{v} + C\hat{w}$. The star operator on 1-forms and 2-forms satisfies

$$\star(Ah_1 du + Bh_2 dv + Ch_3 dw) = Ah_2h_3 dv \wedge dw + Bh_3h_1 dw \wedge du + Ch_1h_2 du \wedge dv \quad (14)$$

For 0-forms and 3-forms, $\star 1 = h_1h_2h_3 du dv dw$.

V. ELECTROSTATICS AND MAGNETOSTATICS

In this section we treat several of the usual elementary applications of Maxwell's laws in integral form. We find the electric flux due to a point charge and a line charge using Gauss's law for the electric field. Ampere's law is used to find the magnetic fields produced by a line current.

A. Point Charge

By symmetry, the tubes of flux from a point charge Q must extend out radially from the charge (Fig. 12), so that

$$D = D_0 r^2 \sin \theta d\theta d\phi \quad (15)$$

To apply Gauss law $\oint_S D = \int_V \rho$, we choose S to be a sphere enclosing the charge. The right-hand side of Gauss's law is equal to Q , and the left-hand side is

$$\begin{aligned} \oint_S D &= \int_0^{2\pi} \int_0^\pi D_0 r^2 \sin \theta d\theta d\phi \\ &= 4\pi r^2 D_0. \end{aligned}$$

Solving for D_0 and substituting into (15),

$$D = \frac{Q}{4\pi r^2} r d\theta r \sin \theta d\phi \text{ C} \quad (16)$$

for the electric flux density due to the point charge. This can also be written

$$D = \frac{Q}{4\pi} \sin \theta d\theta d\phi \text{ C}. \quad (17)$$

Since 4π is the total amount of solid angle for a sphere and $\sin \theta d\theta d\phi$ is the differential element of solid angle, this expression clearly matches Fig. 12 in showing that the amount of flux per solid angle is constant.

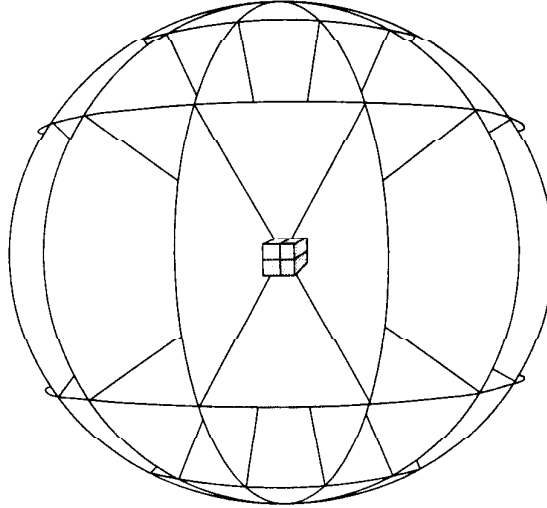

Fig. 12. Electric flux density due to a point charge. Tubes of D extend away from the charge.

B. Line Charge

For a line charge with charge density ρ_l C/m, by symmetry tubes of flux extend out radially from the line, as shown in Fig. 13. The tubes are bounded by the surfaces of $d\phi$ and dz , so that D has the form

$$D = D_0 d\phi dz. \quad (18)$$

Let S be a cylinder of height b with the line charge along its axis. The right-hand side of Gauss's law is

$$\begin{aligned} \int_V \rho &= \int_0^b \rho_l dz \\ &= b\rho_l. \end{aligned}$$

The left-hand side is

$$\begin{aligned} \oint_S D &= \int_0^b \int_0^{2\pi} D_0 d\phi dz \\ &= 2\pi b D_0. \end{aligned}$$

Solving for D_0 and substituting into (18), we obtain

$$D = \frac{\rho_l}{2\pi} d\phi dz \quad C \tag{19}$$

for the electric flux density due to the line charge.

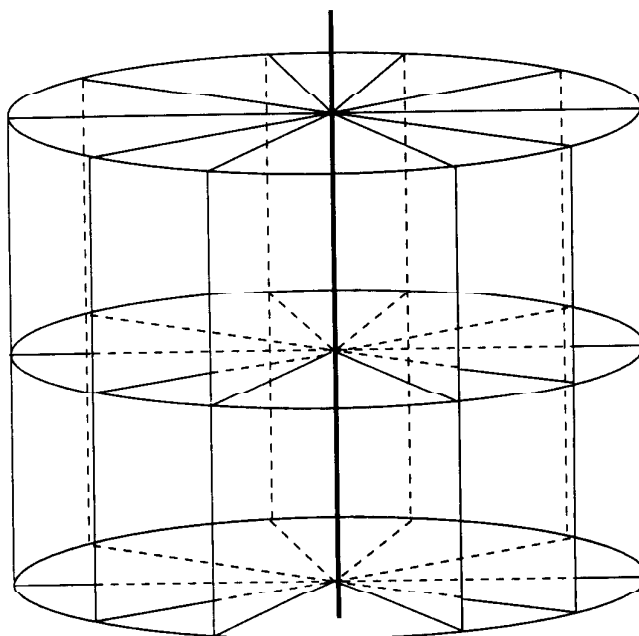

Fig. 13. Electric flux density due to a line charge. Tubes of D extend radially away from the vertical line of charge.

C. Line Current

If a current I_l A flows along the z -axis, sheets of the H 1-form will extend out radially from the current, as shown in Fig. 14. These are the surfaces of $d\phi$, so that by symmetry,

$$H = H_0 d\phi \tag{20}$$

where H_0 is a constant we need to find using Ampere's law. We choose the path P in Ampere's law $\oint_P H = \frac{\partial}{\partial t} \int_A D + \int_A J$ to be a loop around the z -axis. Assuming that $D = 0$, the right-hand side of

Ampere's law is equal to I_l . The left-hand side is the integral of H over the loop,

$$\begin{aligned}\oint_P H &= \int_0^{2\pi} H_0 d\phi \\ &= 2\pi H_0.\end{aligned}$$

The magnetic field intensity is then

$$H = \frac{I_l}{2\pi} d\phi \text{ A} \quad (21)$$

for the line current source.

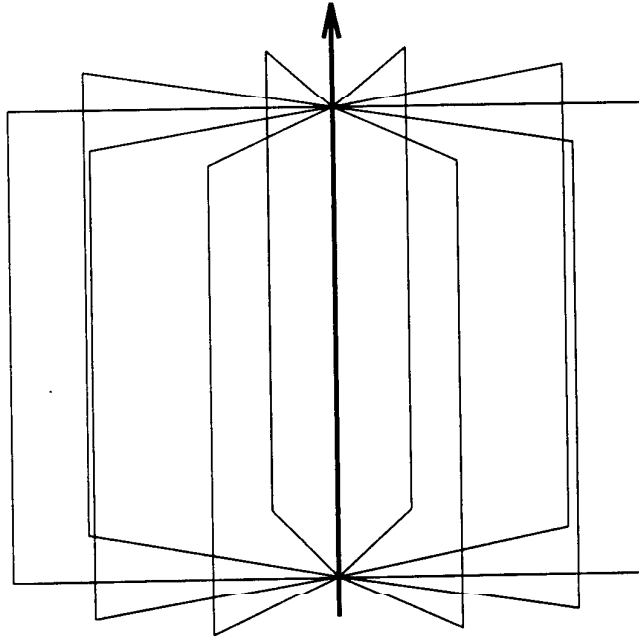

Fig. 14. Magnetic field intensity H due to a line current.

VI. THE EXTERIOR DERIVATIVE AND MAXWELL'S LAWS IN POINT FORM

In this section we introduce the exterior derivative and the generalized Stokes theorem and use these to express Maxwell's laws in point form. The exterior derivative is a single operator which has the gradient, curl, and divergence as special cases, depending on the degree of the differential form on which the exterior derivative acts. The exterior derivative has the symbol d , and can be written formally as

$$d \equiv \frac{\partial}{\partial x} dx + \frac{\partial}{\partial y} dy + \frac{\partial}{\partial z} dz. \quad (22)$$

The exterior derivative can be thought of as implicit differentiation with new differentials introduced from the left.

A. Exterior Derivative of 0-forms

Consider the 0-form $f(x, y, z)$. If we implicitly differentiate f with respect to each of the coordinates, we obtain

$$df = \frac{\partial f}{\partial x} dx + \frac{\partial f}{\partial y} dy + \frac{\partial f}{\partial z} dz. \quad (23)$$

which is a 1-form, the exterior derivative of f . Note that the differentials dx , dy , and dz are the exterior derivatives of the coordinate functions x , y , and z . The 1-form df is dual to the gradient of f .

If ϕ represents a scalar electric potential, the negative of its exterior derivative is electric field intensity:

$$E = -d\phi.$$

As noted earlier, the surfaces of the 1-form E are equipotentials, or level sets of the function ϕ , so that the exterior derivative of a 0-form has a simple graphical interpretation.

B. Exterior Derivative of 1-forms

The exterior derivative of a 1-form is analogous to the vector curl operation. If E is an arbitrary 1-form $E_1 dx + E_2 dy + E_3 dz$, then the exterior derivative of E is

$$\begin{aligned} dE &= \left(\frac{\partial}{\partial x} E_1 dx + \frac{\partial}{\partial y} E_1 dy + \frac{\partial}{\partial z} E_1 dz \right) dx \\ &\quad + \left(\frac{\partial}{\partial x} E_2 dx + \frac{\partial}{\partial y} E_2 dy + \frac{\partial}{\partial z} E_2 dz \right) dy \\ &\quad + \left(\frac{\partial}{\partial x} E_3 dx + \frac{\partial}{\partial y} E_3 dy + \frac{\partial}{\partial z} E_3 dz \right) dz \end{aligned}$$

Using the antisymmetry of the exterior product, this becomes

$$dE = \left(\frac{\partial E_3}{\partial y} - \frac{\partial E_2}{\partial z} \right) dy dz + \left(\frac{\partial E_1}{\partial z} - \frac{\partial E_3}{\partial x} \right) dz dx + \left(\frac{\partial E_2}{\partial x} - \frac{\partial E_1}{\partial y} \right) dx dy, \quad (24)$$

which is a 2-form dual to the curl of the vector field $E_1 \hat{x} + E_2 \hat{y} + E_3 \hat{z}$.

Any 1-form E for which $dE = 0$ is called *closed* and represents a conservative field. Surfaces representing different potential values can never meet. If $dE \neq 0$, the field is non-conservative, and surfaces meet or end wherever the exterior derivative is nonzero.

C. Exterior Derivative of 2-forms

The exterior derivative of a 2-form is computed by the same rule as for 0-forms and 1-forms: take partial derivatives by each coordinate variable and add the corresponding differential on the left. For an arbitrary 2-form B ,

$$\begin{aligned} dB &= \left(\frac{\partial}{\partial x} B_1 dx + \frac{\partial}{\partial y} B_1 dy + \frac{\partial}{\partial z} B_1 dz \right) dy dz \\ &\quad + \left(\frac{\partial}{\partial x} B_2 dx + \frac{\partial}{\partial y} B_2 dy + \frac{\partial}{\partial z} B_2 dz \right) dz dx \\ &\quad + \left(\frac{\partial}{\partial x} B_3 dx + \frac{\partial}{\partial y} B_3 dy + \frac{\partial}{\partial z} B_3 dz \right) dx dy \\ &= \left(\frac{\partial B_1}{\partial x} + \frac{\partial B_2}{\partial y} + \frac{\partial B_3}{\partial z} \right) dx dy dz \end{aligned}$$

where six of the terms vanish due to repeated differentials. The coefficient of the resulting 3-form is the divergence of the vector field dual to B .

D. Properties of the Exterior Derivative

Because the exterior derivative unifies the gradient, curl, and divergence operators, many common vector identities become special cases of simple properties of the exterior derivative. The equality of mixed partial derivatives leads to the identity

$$dd = 0, \quad (25)$$

so that the exterior derivative applied twice yields zero. This relationship is equivalent to the vector relationships $\nabla \times (\nabla f) = 0$ and $\nabla \cdot (\nabla \times \mathbf{A}) = 0$. The exterior derivative also obeys the product rule

$$d(\alpha \wedge \beta) = d\alpha \wedge \beta + (-1)^p \alpha \wedge d\beta \quad (26)$$

where p is the degree of α . A special case of (26) is

$$\nabla \cdot (\mathbf{A} \times \mathbf{B}) = \mathbf{B} \cdot (\nabla \times \mathbf{A}) - \mathbf{A} \cdot (\nabla \times \mathbf{B}).$$

These and other vector identities are often placed in reference tables; by contrast, (25) and (26) are easily remembered.

The exterior derivative in cylindrical coordinates is

$$d = \frac{\partial}{\partial \rho} d\rho + \frac{\partial}{\partial \phi} d\phi + \frac{\partial}{\partial z} dz \quad (27)$$

which is the same as for rectangular coordinates but with the coordinates ρ, ϕ, z in the place of x, y, z . Note that the exterior derivative does not require the factor of ρ that is involved in converting forms to vectors and applying the star operator. In spherical coordinates,

$$d = \frac{\partial}{\partial r} dr + \frac{\partial}{\partial \theta} d\theta + \frac{\partial}{\partial \phi} d\phi \quad (28)$$

where the factors r and $r \sin \theta$ again are not found in the exterior derivative operator. The exterior derivative is

$$d = \frac{\partial}{\partial u} du + \frac{\partial}{\partial v} dv + \frac{\partial}{\partial w} dw \quad (29)$$

in general orthogonal coordinates. The exterior derivative is much easier to apply in curvilinear coordinates than the vector derivatives; there is no need for reference tables of derivative formulas in various coordinate systems.

E. The Generalized Stokes Theorem

The exterior derivative satisfies the generalized Stokes theorem, which states that for any p -form ω ,

$$\int_M d\omega = \oint_{bd M} \omega \quad (30)$$

where M is a $(p+1)$ -dimensional region of space and $bd M$ is its boundary. If ω is a 0-form, then the Stokes theorem becomes $\int_a^b df = f(b) - f(a)$. This is the fundamental theorem of calculus.

If ω is a 1-form, then $bd M$ is a closed loop and M is a surface that has the path as its boundary. This case is analogous to the vector Stokes theorem. Graphically, the number of surfaces of ω pierced by the loop equals the number of tubes of the 2-form $d\omega$ that pass through the loop (Fig. 15).

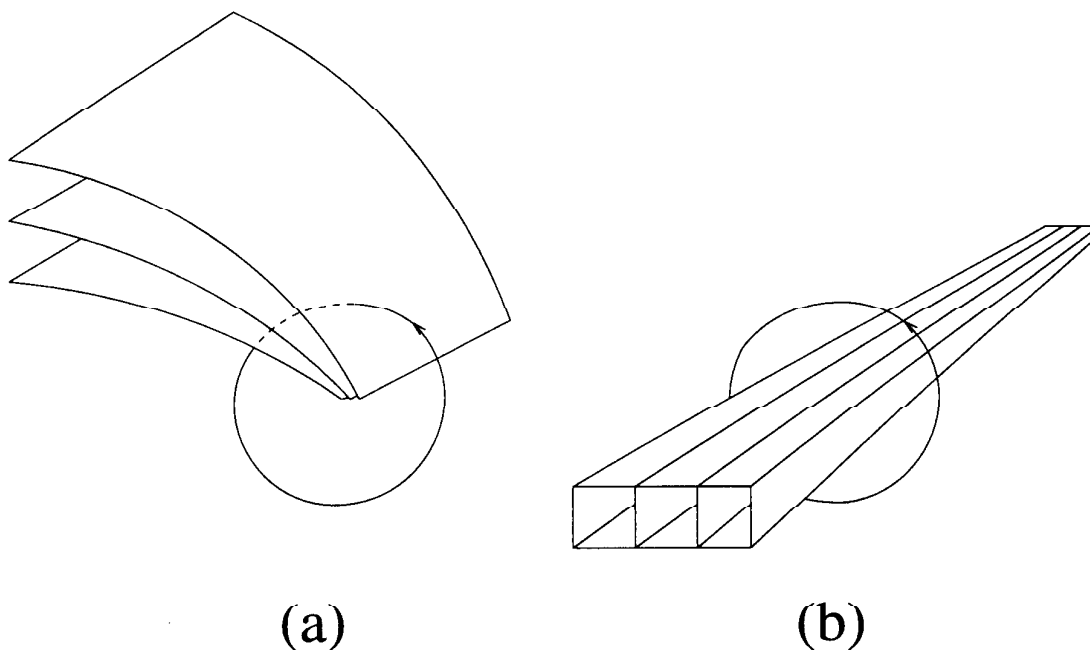

Fig. 15. The Stokes theorem for ω a 1-form. (a) The loop $bd M$ pierces three of the surfaces of ω . (b) Three tubes of $d\omega$ pass through any surface M bounded by the loop $bd M$.

If ω is a 2-form, then $bd M$ is a closed surface and M is the volume inside it. The Stokes theorem requires that the number of tubes of ω that cross the surface equal the number of boxes of $d\omega$ inside the surface, as shown in Fig. 16. This is equivalent to the vector divergence theorem.

Compared to the usual formulations of these theorems,

$$\begin{aligned}
 f(b) - f(a) &= \int_a^b \frac{\partial f}{\partial x} dx \\
 \oint_{bd A} \mathbf{E} \cdot d\mathbf{l} &= \int_A \nabla \times \mathbf{E} \cdot d\mathbf{A} \\
 \oint_{bd V} \mathbf{D} \cdot d\mathbf{S} &= \int_V \nabla \cdot \mathbf{D} dv
 \end{aligned}$$

the generalized Stokes theorem is simpler in form and hence easier to remember. It also makes clear that the vector Stokes theorem and the divergence theorem are higher-dimensional statements of the fundamental theorem of calculus.

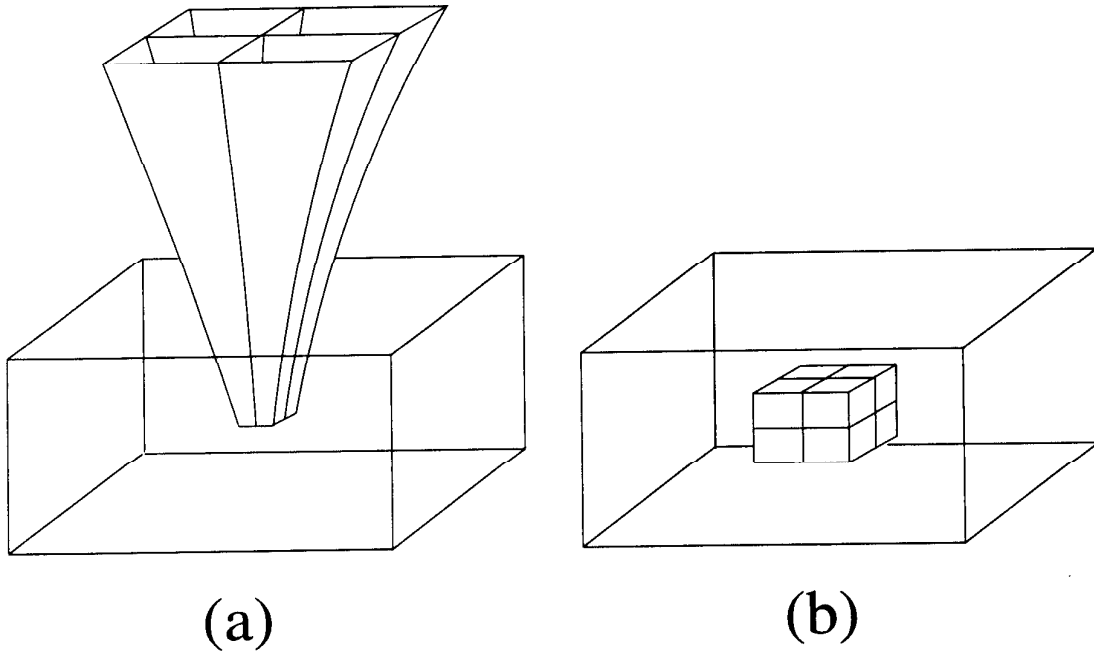

Fig. 16. Stokes theorem for ω a 2-form. (a) Four tubes of the 2-form ω pass through a surface. (b) The same number of boxes of the 3-form $d\omega$ lie inside the surface.

F. Faraday's and Ampere's Laws in Point Form

Faraday's law in integral form is

$$\oint_P E = -\frac{\partial}{\partial t} \int_A B. \quad (31)$$

Using the Stokes theorem, taking M to be the surface A , we can relate the path integral of E to the surface integral of the exterior derivative of E ,

$$\oint_P E = \int_A dE. \quad (32)$$

By Faraday's law,

$$\int_A dE = -\frac{\partial}{\partial t} \int_A B. \quad (33)$$

For sufficiently regular forms E and B , we have that

$$dE = -\frac{\partial}{\partial t} B \quad (34)$$

since (33) is valid for all surfaces A . This is Faraday's law in point form. This law states that new surfaces of E are produced by tubes of time-varying magnetic flux.

Using the same argument, Ampere's law becomes

$$dH = \frac{\partial}{\partial t} D + J. \quad (35)$$

Ampere's law shows that new surfaces of H are produced by tubes of time-varying electric flux or electric current.

G. Gauss's Laws in Point Form

Gauss's law for the electric flux density is

$$\oint_S D = \int_V \rho. \quad (36)$$

The Stokes theorem with M as the volume V and $bd M$ as the surface S shows that

$$\oint_S D = \int_V dD. \quad (37)$$

Using Gauss's law in integral form (36),

$$\int_V dD = \int_V \rho. \quad (38)$$

We can then write

$$dD = \rho. \quad (39)$$

This is Gauss's law for the electric field in point form. Graphically, this law shows that tubes of electric flux density can end only on electric charges. Similarly, Gauss's law for the magnetic field is

$$dB = 0. \quad (40)$$

This law requires that tubes of magnetic flux density never end; they must form closed loops or extend to infinity.

H. Poynting's Theorem

Using Maxwell's laws, we can derive a conservation law for electromagnetic energy. The exterior derivative of S is

$$\begin{aligned} dS &= d(E \wedge H) \\ &= (dE) \wedge H - E \wedge (dH) \end{aligned}$$

Using Ampere's and Faraday's laws, this can be written

$$dS = -\frac{\partial}{\partial t} B \wedge H - E \wedge \frac{\partial}{\partial t} D - E \wedge J \quad (41)$$

Finally, using the definition (6) of w , this becomes

$$dS = -\frac{\partial w}{\partial t} - E \wedge J. \quad (42)$$

At a point where no sources exist, a change in stored electromagnetic energy must be accompanied by tubes of S that represent flow of energy towards or away from the point.

I. Integrating Forms by Pullback

We have seen in previous sections that differential forms give integration a clear graphical interpretation. The use of differential forms also results in several simplifications of the integration process itself. Integrals of vector fields require a metric; integrals of differential forms do not. The method of pullback replaces the computation of differential length and surface elements that is required before a vector field can be integrated.

Consider the path integral

$$\int_P \mathbf{E} \cdot d\mathbf{l}. \quad (43)$$

The dot product of \mathbf{E} with $d\mathbf{l}$ produces a 1-form with a single differential in the parameter of the path P , allowing the integral to be evaluated. The integral of the 1-form E dual to \mathbf{E} over the same path is computed by the method of *pullback*, as change of variables for differential forms is commonly termed. Let the path P be parameterized by

$$x = p_1(t), \quad y = p_2(t), \quad z = p_3(t)$$

for $a < t < b$. The pullback of E to the path P is denoted P^*E , and is defined to be

$$\begin{aligned} P^*E &= P^*(E_1 dx + E_2 dy + E_3 dz) \\ &= E_1(p_1, p_2, p_3)dp_1 + E_2(p_1, p_2, p_3)dp_2 + E_3(p_1, p_2, p_3)dp_3 \\ &= \left(E_1(p_1, p_2, p_3) \frac{\partial p_1}{\partial t} + E_2(p_1, p_2, p_3) \frac{\partial p_2}{\partial t} + E_3(p_1, p_2, p_3) \frac{\partial p_3}{\partial t} \right) dt. \end{aligned}$$

Using the pullback of E , we convert the integral over P to an integral in t over the interval $[a, b]$,

$$\int_P E = \int_a^b P^*E \quad (44)$$

Components of the Jacobian matrix of the coordinate transform from the original coordinate system to the parameterization of the region of integration enter naturally when the exterior derivatives are performed. Pullback works similarly for 2-forms and 3-forms, allowing evaluation of surface and volume integrals by the same method. The following example illustrates the use of pullback.

Example 3. Work required to move a charge through an electric field.

Let the electric field intensity be given by $E = 2xy dx + x^2 dy - dz$. A charge of $q = 1 C$ is transported over the path P given by $(x = t^2, y = t, z = 1 - t^3)$ from $t = 0$ to $t = 1$. The work required is given by

$$W = -q \int_P 2xy dx + x^2 dy - dz \quad (45)$$

which by Eq. (44) is equal to

$$= -q \int_0^1 P^*(2xy dx + x^2 dy - dz)$$

where P^*E is the pullback of the field 1-form to the path P ,

$$\begin{aligned} P^*E &= 2(t^2)(t)2t dt + (t^2)^2 dt - (-3t^2) dt \\ &= (5t^4 + 3t^2) dt. \end{aligned}$$

Integrating this new 1-form in t over $[0, 1]$, we obtain

$$W = - \int_0^1 (5t^4 + 3t^2) dt = -2 J$$

as the total work required to move the charge along P .

J. Summary

Throughout this section, we have noted various aspects of the calculus of differential forms that simplify manipulations and provide insight into the principles of electromagnetics. The exterior derivative behaves differently depending on the degree of the form it operates on, so that physical properties of a field are encoded in the type of form used to represent it, rather than in the type of operator used to take its derivative. The generalized Stokes theorem gives the vector Stokes theorem and the divergence theorem intuitive graphical interpretations that illuminate the relationship between the two theorems. While of lesser pedagogical importance, the algebraic and computational advantages of forms cited in this section also aid students by reducing the need for reference tables or memorization of identities.

VII. THE INTERIOR PRODUCT AND BOUNDARY CONDITIONS

Boundary conditions can be expressed using a combination of the exterior and interior products. The same operator is used to express boundary conditions for field intensities and flux densities, and in both cases the boundary conditions have simple graphical interpretations.

A. The Interior Product

The interior product has the symbol \lrcorner . Graphically, the interior product removes the surfaces of the first form from those of the second. The interior product $dx \lrcorner dy = 0$, since there are no dy surfaces to remove. The interior product of dx with itself is one. The interior product of dx and $dx dy$ is $dx \lrcorner dx dy = dy$. To compute the interior product $dy \lrcorner dx dy$, the differential dy must be moved to the left of $dx dy$ before it can be removed, so that

$$\begin{aligned} dy \lrcorner dx dy &= -dy \lrcorner dy dx \\ &= -dx. \end{aligned}$$

The interior product of arbitrary 1-forms can be found by linearity from the relationships

$$\begin{aligned} dx \lrcorner dx &= 1, & dx \lrcorner dy &= 0, & dx \lrcorner dz &= 0 \\ dy \lrcorner dx &= 0, & dy \lrcorner dy &= 1, & dy \lrcorner dz &= 0 \\ dz \lrcorner dx &= 0, & dz \lrcorner dy &= 0, & dz \lrcorner dz &= 1. \end{aligned} \tag{46}$$

The interior product of a 1-form and a 2-form can be found using

$$\begin{aligned} dx \lrcorner dy \wedge dz &= 0, & dx \lrcorner dz \wedge dx &= -dz, & dx \lrcorner dx \wedge dy &= dy \\ dy \lrcorner dy \wedge dz &= dz, & dy \lrcorner dz \wedge dx &= 0, & dy \lrcorner dx \wedge dy &= -dx \\ dz \lrcorner dy \wedge dz &= -dy, & dz \lrcorner dz \wedge dx &= dx, & dz \lrcorner dx \wedge dy &= 0. \end{aligned} \quad (47)$$

The following examples illustrate the use of the interior product.

Example 4. The Interior Product of two 1-forms

The interior product of $a = 3x dx - y dz$ and $b = 4 dy + 5 dz$ is

$$\begin{aligned} a \lrcorner b &= (3x dx - y dz) \lrcorner (4 dy + 5 dz) \\ &= 12x dx \lrcorner dy + 15x dx \lrcorner dz - 4y dz \lrcorner dy - 5y dz \lrcorner dz \\ &= -5y \end{aligned}$$

which is the dot product $\mathbf{a} \cdot \mathbf{b}$ of the vectors dual to the 1-forms a and b .

Example 5. The Interior Product of a 1-form and a 2-form

The interior product of $a = 3x dx - y dz$ and $c = 4 dz dx + 5 dx dy$ is

$$\begin{aligned} a \lrcorner c &= (3x dx - y dz) \lrcorner (4 dz dx + 5 dx dy) \\ &= 12x dx \lrcorner dz dx + 15x dx \lrcorner dx dy - 4y dz \lrcorner dz dx - 5y dz \lrcorner dx dy \\ &= -12x dz + 15x dy - 4y dx \end{aligned}$$

which is the 1-form dual to $-\mathbf{a} \times \mathbf{c}$, where \mathbf{a} and \mathbf{c} are dual to a and c .

The interior product can be related to the exterior product using the star operator. The interior product of arbitrary forms a and b is

$$a \lrcorner b = \star(\star b \wedge a) \quad (48)$$

which can be used to compute the interior product in curvilinear coordinate systems. (This formula shows the metric dependence of the interior product as we have defined it; the interior product is usually defined to be the contraction of a vector with a form, which is independent of any metric.) The interior and exterior products satisfy the identity

$$\alpha = n \wedge (n \lrcorner \alpha) + n \lrcorner (n \wedge \alpha) \quad (49)$$

where α is an arbitrary form.

The Lorentz force law can be expressed using the interior product. The force 1-form F is

$$F = q(E - \mathbf{v} \lrcorner B) \quad (50)$$

where \mathbf{v} is the velocity of a charge q , and the interior product can be computed by finding the 1-form dual to \mathbf{v} and using the rules given above. F is dual to the usual force vector \mathbf{F} . The force 1-form has units of energy, and does not have as clear a physical interpretation as the usual force vector. In this case we prefer

to work with the vector dual to F , rather than F itself. Force, like displacement and velocity, is naturally a vector quantity.

B. Boundary Conditions

A boundary can be specified as the set of points satisfying $f(x, y, z) = 0$ for some suitable function f . The surface normal 1-form is defined to be the normalized exterior derivative of f ,

$$n = \frac{df}{\sqrt{(df \lrcorner df)}}. \quad (51)$$

The surfaces of n are parallel to the boundary. Using a subscript 1 to denote the region where $f > 0$, and a subscript 2 for $f < 0$, the four electromagnetic boundary conditions can be written [18]

$$\begin{aligned} n \lrcorner (n \wedge (E_1 - E_2)) &= 0 \\ n \lrcorner (n \wedge (H_1 - H_2)) &= J_s \\ n \lrcorner (n \wedge (D_1 - D_2)) &= \rho_s \\ n \lrcorner (n \wedge (B_1 - B_2)) &= 0 \end{aligned}$$

where J_s is the surface current density 2-form and ρ_s is the surface charge density 2-form. The operator $n \lrcorner n \wedge$ projects an arbitrary form to its component that has nonzero integral along the boundary.

C. Surface Current

The field intensity boundary conditions can be stated simply: surfaces of the 1-form $H_1 - H_2$ end along lines of the surface current density 1-form J_s . Surfaces of $E_1 - E_2$ cannot intersect a boundary at all.

The action of the operator $n \lrcorner n \wedge$ can also be interpreted graphically. Consider the field discontinuity $H_1 - H_2$ shown in Fig. 17a. The exterior product of n and $H_1 - H_2$ is a 2-form with tubes that run parallel to the boundary, as shown in Fig. 17b. The component of $H_1 - H_2$ with surfaces parallel to the boundary is removed. The interior product $n \lrcorner (n \wedge (H_1 - H_2))$ removes the surfaces parallel to the boundary, leaving only surfaces perpendicular to the boundary, as in Fig. 17c. Current flows along the lines where the surfaces intersect the boundary. The direction of flow along the lines of the 1-form can be found using the right-hand rule on the direction of $H_1 - H_2$ in region 1 above the boundary.

Unlike other electromagnetic quantities, J_s is not dual to the vector \mathbf{J}_s . The direction of \mathbf{J}_s is parallel to the lines of J_s in the boundary, as shown in Fig. 17c. (J_s is a twisted differential form, so that under coordinate inversion it transforms with a minus sign relative to a nontwisted 1-form. This property is discussed in detail in Refs. [3], [18], [21]. Operationally, the distinction can be ignored as long as one remains in right-handed coordinates.) J_s is natural both mathematically and geometrically as a representation of surface current density. The expression for current through a path using the vector surface current density is

$$I = \int_P \mathbf{J}_s \cdot (\hat{\mathbf{n}} \times d\hat{\mathbf{l}}) \quad (52)$$

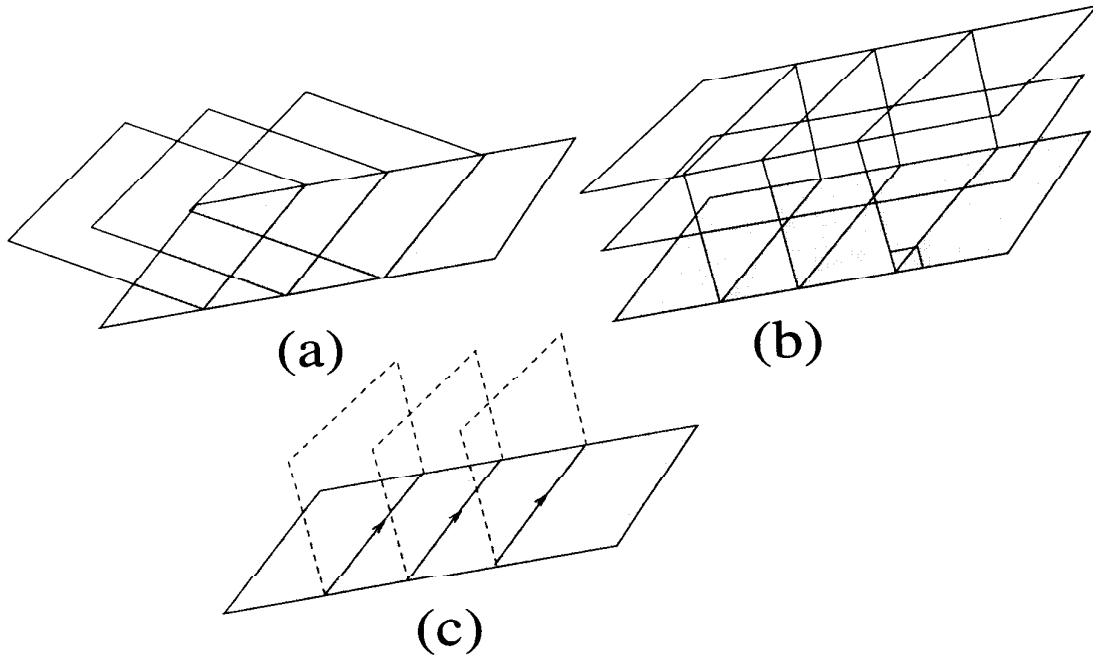

Fig. 17. (a) The 1-form $H_1 - H_2$. (b) The 2-form $n \wedge (H_1 - H_2)$. (c) The 1-form J_s , represented by lines on the boundary. Current flows along the lines.

where \hat{n} is a surface normal. This simplifies to

$$I = \int_P J_s \quad (53)$$

using the 1-form J_s . Note that J_s changes sign depending on the labeling of regions one and two; this ambiguity is precisely equivalent to the existence of two choices for \hat{n} in Eq. (52).

The following example illustrates the boundary condition on the magnetic field intensity.

Example 6. Surface current on a sinusoidal surface

A sinusoidal boundary given by $z = \cos y$ has magnetic field intensity $H_1 = dx$ A above and zero below. The surface normal 1-form is

$$n = \frac{\sin y \, dy + dz}{\sqrt{1 + \sin^2 y}}$$

By the boundary conditions given above,

$$\begin{aligned} J_s &= n \lrcorner (n \wedge dx) \\ &= \frac{1}{1 + \sin^2 y} (\sin y \, dy + dz) \lrcorner (\sin y \, dy \, dz + dz \, dx) \\ &= \frac{dx + \sin^2 y \, dx}{1 + \sin^2 y} \\ &= dx \text{ A.} \end{aligned}$$

The usual vector \mathbf{J}_s is $\frac{y - \sin y \mathbf{z}}{\sqrt{1 + \sin^2 y}}$ which clearly is not dual to dx . The direction of the vector is parallel to the lines of J_s on the boundary.

D. Surface Charge

The flux density boundary conditions are equally intuitive: tubes of the difference $D_1 - D_2$ in electric flux densities on either side of a boundary intersect the boundary to form boxes of surface charge density. Tubes of the discontinuity in magnetic flux density cannot intersect the boundary.

Figure 18a shows the 2-form $D_1 - D_2$. The exterior product $n \wedge (D_1 - D_2)$ yields boxes that have sides parallel to the boundary, as shown in Fig. 18b. The component of $D_1 - D_2$ with tubes parallel to the boundary is removed by the exterior product. The interior product with n removes the surfaces parallel to the boundary, leaving tubes perpendicular to the boundary. These tubes intersect the boundary to form boxes of charge (Fig. 18c). This is the 2-form $\rho_s = n \lrcorner (n \wedge (D_1 - D_2))$.

The sign of the charge on the boundary can be obtained from the direction of $D_1 - D_2$ in region 1 above the boundary, which must point away from positive charge and towards negative charge. The integral of ρ_s over a surface,

$$Q = \int_S \rho_s \tag{54}$$

yields the total charge on the surface. Note that ρ_s changes sign depending on the labeling of regions one and two. This ambiguity is equivalent to the existence of two choices for the area element dA and orientation of the area A in the integral $\int_A q_s dA$, where q_s is the usual scalar surface charge density. In many cases, the sign of the value of the integral is known before it is integrated, and this subtlety goes unnoticed.

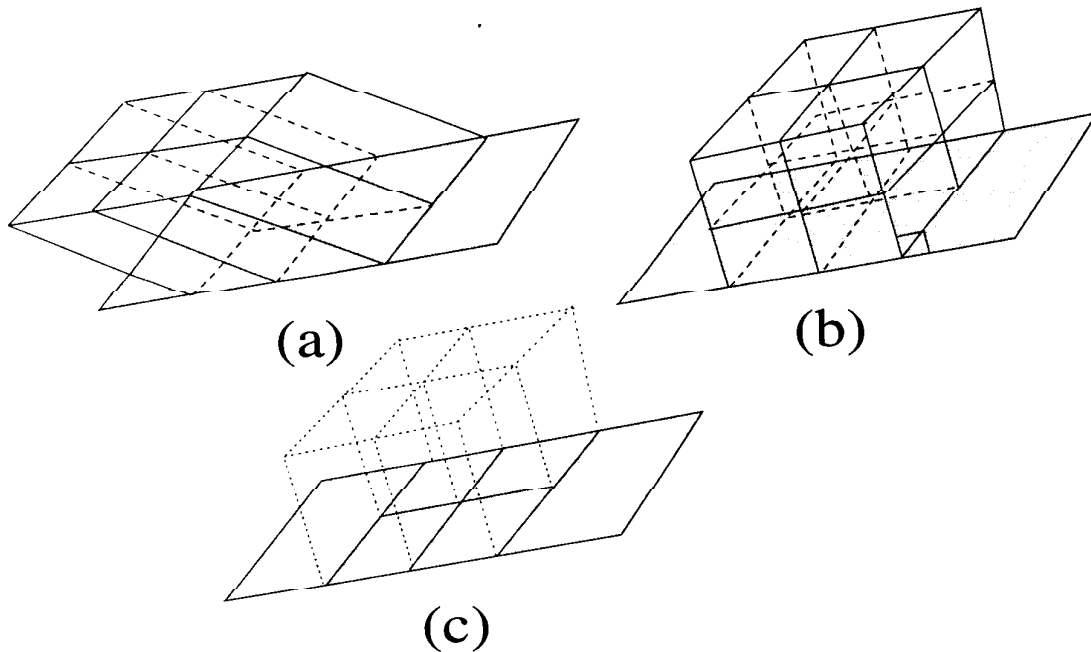

Fig. 18. (a) The 2-form $D_1 - D_2$. (b) The 3-form $n \wedge (D_1 - D_2)$, with sides perpendicular to the boundary. (c) The 2-form ρ_s , represented by boxes on the boundary.

VIII. CONCLUSION

The primary pedagogical advantages of differential forms are the distinct representations of field intensity and flux density, intuitive graphical representations of each of Maxwell's laws, and a simple picture of electromagnetic boundary conditions. Differential forms provide visual models that can help students remember and apply the principles of electromagnetics. Computational simplifications also result from the use of forms: derivatives are easier to employ in curvilinear coordinates, integration becomes more straightforward, and families of related vector identities are replaced by algebraic rules. These advantages over traditional methods make the calculus of differential forms ideal as a language for teaching electromagnetic field theory.

The reader will note that we have omitted important aspects of forms. In particular, we have not discussed forms as linear operators on vectors, or covectors, focusing instead on the integral point of view. Other aspects of electromagnetics, including the vector potentials, Green functions, and wave propagation also benefit from the use of differential forms.

Ideally, the electromagnetics curriculum set forth in this paper would be taught in conjunction with calculus courses employing differential forms. A unified curriculum, although desirable, is not necessary in order for students to profit from the use of differential forms. We have found that because of the simple correspondence between vectors and forms, the transition from vector analysis to differential forms is generally quite easy for students to make. Familiarity with vector analysis also helps students to recognize and appreciate the advantages of the calculus of differential forms over other methods.

We hope that this attempt at making differential forms accessible at the undergraduate level helps to fulfill the vision expressed by Deschamps [2] and others, that students obtain the power, insight, and clarity that differential forms offer to electromagnetic field theory and its applications.

REFERENCES

- [1] C. Misner, K. Thorne, and J. A. Wheeler, *Gravitation*, Freeman, San Francisco, 1973.
- [2] G. A. Deschamps, "Electromagnetics and differential forms," *IEEE Proc.*, vol. 69, no. 6, pp. 676–696, June 1981.
- [3] William L. Burke, *Applied Differential Geometry*, Cambridge University Press, Cambridge, 1985.
- [4] C. Nash and S. Sen, *Topology and geometry for physicists*, Academic Press, San Diego, California, 1983.
- [5] P. Bamberg and S. Sternberg, *A Course in Mathematics for Students of Physics*, vol. II, Cambridge University Press, Cambridge, 1988.
- [6] H. Flanders, *Differential Forms with Applications to the Physical Sciences*, Dover, New York, New York, 1963.
- [7] Y. Choquet-Bruhat and C. DeWitt-Morette, *Analysis, Manifolds and Physics*, North-Holland, Amsterdam, 1982.
- [8] S. Hassani, *Foundations of Mathematical Physics*, Allyn and Bacon, Boston, 1991.
- [9] Robert Hermann, *Topics in the geometric theory of linear systems*, Math Sci Press, Brookline, MA, 1984.
- [10] D. Baldomir, "Differential forms and electromagnetism in 3-dimensional Euclidean space \mathbb{R}^3 ," *IEE Proc.*, vol. 133, no. 3, pp. 139–143, May 1986.
- [11] N. Schleifer, "Differential forms as a basis for vector analysis—with applications to electrodynamics," *Am. J. Phys.*, vol. 51, no. 12, pp. 1139–1145, Dec. 1983.
- [12] D. B. Nguyen, "Relativistic constitutive relations, differential forms, and the p-compound," *Am. J. Phys.*, vol. 60, no. 12, pp. 1137–1147, Dec. 1992.
- [13] D. Baldomir and P. Hammond, "Global geometry of electromagnetic systems," *IEE Proc.*, vol. 140, no. 2, pp. 142–150, Mar. 1992.
- [14] P. Hammond and D. Baldomir, "Dual energy methods in electromagnetics using tubes and slices," *IEE Proc.*, vol. 135, no. 3A, pp. 167–172, Mar. 1988.
- [15] R. S. Ingarden and A. Jamiolkowski, *Classical Electrodynamics*, Elsevier, Amsterdam, The Netherlands, 1985.
- [16] S. PARTOLL, *Relativistic Electrodynamics and Differential Geometry*, Springer-Verlag, New York, 1987.
- [17] Walter Thirring, *Classical Field Theory*, vol. II, Springer-Verlag, New York, 1978.
- [18] K. F. Warnick, R. H. Selfridge, and D. V. Arnold, "Electromagnetic boundary conditions using differential forms," *IEE Proc.*, vol. 142, no. 4, pp. 326–332, 1995.
- [19] K. F. Warnick and D. V. Arnold, "Electromagnetic green functions using differential forms," *Journal of Electromagnetic Waves and Applications*, vol. 10, no. 3, pp. 427–438, 1996.
- [20] K. F. Warnick and D. V. Arnold, "Differential forms in electromagnetic field theory," *Antennas and Propagation Symposium Proceedings*, To Appear, 1996.
- [21] William L. Burke, "Manifestly parity invariant electromagnetic theory and twisted tensors," *J. Math. Phys.*, vol. 24, no. 1, pp. 65–69, Jan. 1983.